



MaxPure6Mo Bio-Pharm Equipment

Super Austenitic Alloys for Superior Corrosion Resistance

 MaxPure Series
6Mo | **316L**

 **NEUMO**  **VNE**  **EGMO**
NEUMO Ehrenberg Group



MaxPure6Mo Bio-Pharm Equipment

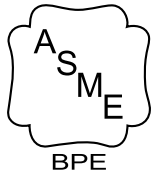

6Mo

MaxPure 6Mo is the leading brand for high alloys in clean industries. The fittings and tubes are manufactured from super austenitic alloys containing 6% Molybdenum. It provides superior corrosion resistance for the most aggressive applications in the sanitary and high purity industries.

Our MaxPure6Mo products proudly offer:

Superior Corrosion Resistance

6% Molybdenum superaustenitic stainless steel with outstanding resistance to chloride pitting, crevice corrosion and stress-corrosion cracking

Maximum Cleanability

MaxPure 6Mo fittings are cleaned using a multiple step process to assure clean surface, areas inside and out with repeatability every time.

Every fitting is passivated according to ASME BPE and ASTM A967 standards.

Full Traceability

We provide full traceability for each of our products by supplying all necessary production process data. Starting from certifications and incoming inspection of raw materials, through in-process quality control, final inspection, marking and packaging. The process is also completely documented with a unique job number for each BPE process component.

Every Fitting is Quality Inspected

All around quality and meticulous inspection insures that every fitting will be of the highest quality and in total compliance with all ASME-BPE standards. MaxPure 6Mo fittings are 100% visual inspected.

Additional in MaxPure Series

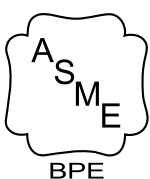

316L

MaxPure ASME BPE is the leading brand for fittings to the pharmaceutical industry. The items are manufactured from 316L stainless steel with sulfur content of 0.005%-0.017%. MaxPure fittings meet all the strict requirements of the ASME BPE according the latest edition.

Introduction

Due to an increasing demand of various industries for superior corrosion resistance alloys for sanitary and high purity process systems, many industries are now using corrosion-resistant alloys rather than traditional stainless steel (conventional 300 series stainless).

In the high-purity and sanitary industries, products such as: personal care, food (sport drinks, ketchup, salsa) Active Pharmaceutical Ingredients, etc. require extremely superior corrosion-resistant material to withstand the high concentration of chlorides (chemicals), high temperatures, and low PH.

The super-austenitic AL-6XN® alloy (UNS N08367) is one of the materials that has been successfully used in these applications and it is now possible to extend the life of system components that may experience problems with chloride induced corrosion by using AL-6XN® (UNS N08367).

The AL-6XN® alloy (UNS N08367) was designed to be a seawater resistant material and has since been demonstrated to be resistant to a broad range of very corrosive environments.

Super austenitic stainless steels contain high levels of chromium and higher levels of nickel together with additions of molybdenum and nitrogen. The result is a series of austenite, stronger than the conventional 300 series stainless and with improved resistance to chloride stress corrosion cracking, and superior resistance to pitting and crevice corrosion.

Chemical Composition

The typical and specified chemical compositions of AL-6XN® alloy are presented in Table 1.

The chromium, nickel and molybdenum contents are significantly higher in the AL-6XN® alloy than in the standard Type 304L and 316L grades. The alloy has the designation UNS N08367 and is included in appropriate standards in the American Society for Testing and Materials (ASTM) annual book of standards.

ASTM initially classified AL-6XN® alloy with the nonferrous alloys in the “B” specification because the alloy contains slightly less than 50% iron.

Table 1: Chemical Composition (weight %) of AL-6XN® Alloy

Chemical Element	Typical AL-6XN® Alloy	Allowable UNS N08367
C - Carbon	0.020	0.030 maximum
Mn - Manganese	0.400	2.000 maximum
P - Phosphorus	0.020	0.040 maximum
S - Sulfur	0.001	0.030 maximum
Si - Silicon	0.400	1.000 maximum
Cr - Chromium	20.500	20.000 - 22.000
Ni - Nickel	24.000	23.500 - 25.500
Mo - Molybdenum	6.200	6.000 - 7.000
N - Nitrogen	0.220	0.180 - 0.250
Cu - Copper	0.200	0.750 maximum
Fe - Iron	Balance	Balance

Values shown are for comparison only.

Always consult current editions of codes and standards for values for use in design.

Index

Fittings Specifications.....	6
Tube Specifications.....	8
How to Order.....	9
Ordering Information.....	9
Tubes and Fittings	10



Insert Rings | Page 10 |



Elbows | Page 11-12 |



Tees | Page 13-15 |



Reducers | Page 16-18 |



Ferrules | Page 19 |



Solid End Caps & Weld Caps
| Page 20 |

Standard Specifications	21
Physical Properties.....	21
Mechanical Properties.....	22
Material Technical Information.....	23
Working Conditions.....	24
Machinability.....	25
Cutting & Welding.....	26
General Technical Information.....	27
Also Available.....	28
MTR - Material Test Report.....	30
ASME BPE - Certificate.....	31

MaxPure6Mo Fittings Specifications

Product:

Stainless Steel fittings comply with ASME BPE standards.

Gaskets are made from compounds which are FDA approved and USP 87, 88 Pharmaceutical Class VI certified.

Sizes:

Stainless Steel fittings are available in sizes 1/2" - 4" O.D. tube size.

Material:

Fittings are fabricated in AL-6XN® (UNS N08367) Stainless Steel with 6% Molybdenum for superior corrosion resistance.

Dimensions & Tolerances:

Dimensions as specified in ASME BPE Part DT-3-1

Nominal Size	O.D.		Wall Thickness Mechanical Polish (MP)		Wall Thickness Electropolish (EP)		Squareness Face to Tangent, B		Off Angle, 0		Equivalent Angle (for O)	Off Plane, P		Centerline Radius (CLR), R	
	in.	mm	in.	mm	in.	mm	in.	mm	in.	mm	deg	in.	mm	in.	mm
1/2"	±0.005	±0.13	+0.005/-0.008	+0.13/-0.20	+0.005/-0.010	+0.13/-0.25	0.005	0.13	0.014	0.36	1.6	0.030	0.76	1.125	28.58
3/4"	±0.005	±0.13	+0.005/-0.008	+0.13/-0.20	+0.005/-0.010	+0.13/-0.25	0.005	0.13	0.018	0.46	1.4	0.030	0.76	1.125	28.58
1"	±0.005	±0.13	+0.005/-0.008	+0.13/-0.20	+0.005/-0.010	+0.13/-0.25	0.008	0.20	0.025	0.64	1.4	0.030	0.76	1.500	38.10
1 1/2"	±0.008	±0.20	+0.005/-0.008	+0.13/-0.20	+0.005/-0.010	+0.13/-0.25	0.008	0.20	0.034	0.86	1.3	0.050	1.27	2.250	57.15
2"	±0.008	±0.20	+0.005/-0.008	+0.13/-0.20	+0.005/-0.010	+0.13/-0.25	0.008	0.20	0.043	1.09	1.2	0.050	1.27	3.000	76.20
2 1/2"	±0.010	±0.25	+0.005/-0.008	+0.13/-0.20	+0.005/-0.010	+0.13/-0.25	0.010	0.25	0.054	1.37	1.2	0.050	1.27	3.750	95.25
3"	±0.010	±0.25	+0.005/-0.008	+0.13/-0.20	+0.005/-0.010	+0.13/-0.25	0.016	0.41	0.068	1.73	1.3	0.050	1.27	4.500	114.30
4"	±0.015	±0.38	+0.008/-0.010	+0.20/-0.25	+0.008/-0.012	+0.20/-0.30	0.016	0.41	0.086	2.18	1.2	0.060	1.52	6.000	152.40

Roundness

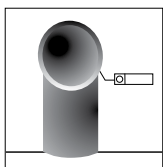

Wall Thickness

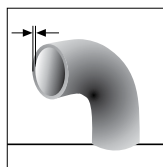

Squareness Face to Tangent

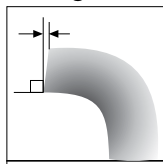

Off Angle

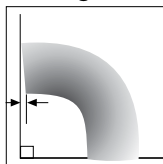

Off Plane

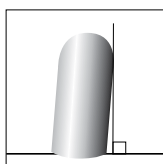

Height

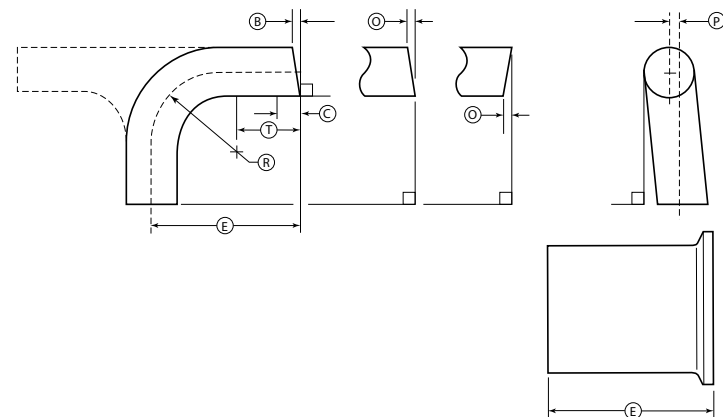
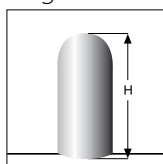

General Notes:

- a. Tolerance on (E) end-to-end and center-to-end: 0.050 in. (1.27 mm)
- b. Tolerance for centerline radius (CLR) is ±10% of the nominal dimension

Fittings Specifications

Surface Finish:

Reference: ASME BPE, Part SF, Table SF-2.4-1.

Surface Finish Code	BPE Surface Designation	Ra Maximum		Inside Surface	Outside Surface
		μ-in.	μm	Surface Condition	Surface Condition
		PL	SF2		
PM	SF5	20	0.51	Mechanically Polished [1] & Electropolished	Mechanically polished to 32 Ra μ-in.

[1] Or any other finishing method that meets the Ra max.

- MaxPure 6Mo fittings guarantee the Ra in all internal surfaces, including bent areas where it is difficult to polish and difficult to measure.
- All Ra readings are taken across the lay, wherever possible.
- No single Ra reading shall exceed the Ra max. value in this table.
- Other Ra readings are available if agreed upon between owner/user and supplier, not to exceed values in this table.

Cleaning:

A multi step cleaning cycle is conducted to ensure that fittings are cleaned with a perfect passivation layer. The cleaning process involves degreasing, pickling, electro polishing (as required) and passivation. During the final stage, the fittings are double-rinsed using D.I. water.

Inspection Procedures:

All fittings produced by EGMO production are 100% visually inspected for any surface finish imperfections, as mentioned in Table SF-2.2-1, SF-2.2-2, SF-2.4-1 and SF 2.6-1 in the ASME BPE specification. All dimensional characteristics are inspected for tolerances listed in parts DT-3-1 to DT-9.3-1 in the ASME BPE specification.

Fitting Marking Information:

Each fitting and process component is permanently laser marked to show the following:

- Job number
- Heat number/code traceable to material test report for each product contact surface component
- Material type
- Manufacturer's name, logo, & trademark
- Product contact surface designation for the appropriate BPE specification
- ASME BPE mark 



Packaging & Labeling:

Each fitting is capped, bagged and labeled in full compliance with the ASME BPE standard. Every label includes a QR Code which directs to the fitting's Material Test Report (Please refer to page 30).

Documentation:

Full Material Test Reports are supplied with the finished products and are available On-Line at www.MaxPure.net

MaxPure6Mo Tube Specifications

Standards:

- ASTM A270-S2 / B676
- ASME SB676
- ASME BPE

Surface Finish:

Surface finish specifications are the same for fittings & tubes.
Please refer to table SF-2.4-1 page 7.

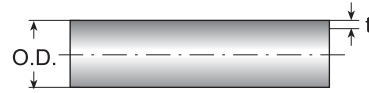

Tubing Dimensional Tolerances

Tubing Diameter		Wall Thickness		OD Tolerance Length (ASTM Spec.)		Length (ASTM Spec.)		Wall Thickness Tolerance
inch	mm.	inch	mm.	inch	mm.	inch	mm.	ASTM Spec.
1/2"	12.70	0.065	1.65	+/- 0.005	+/- 0.129	0.125	3.175	+/- 10%
3/4"	19.05	0.065	1.65	+/- 0.005	+/- 0.130	0.125	3.175	+/- 10%
1"	25.40	0.065	1.65	+/- 0.005	+/- 0.131	0.125	3.175	+/- 10%
1 1/2"	38.10	0.065	1.65	+/- 0.008	+/- 0.203	0.125	3.175	+/- 10%
2"	50.80	0.065	1.65	+/- 0.008	+/- 0.204	0.125	3.175	+/- 10%
2 1/2"	63.50	0.065	1.65	+/- 0.010	+/- 0.254	0.125	3.175	+/- 10%
3"	76.20	0.065	1.65	+/- 0.015	+/- 0.381	0.125	3.175	+/- 10%
4"	101.60	0.083	2.11	+/- 0.015	+/- 0.381	0.188	4.763	+/- 10%



MaxPure6Mo How to Order

To specify the part completely, start with the product description and select the additional options as shown below:

Ordering example (Fitting): 90° weld ends elbow 6MO Alloy, 1/2" size, PL surface finish

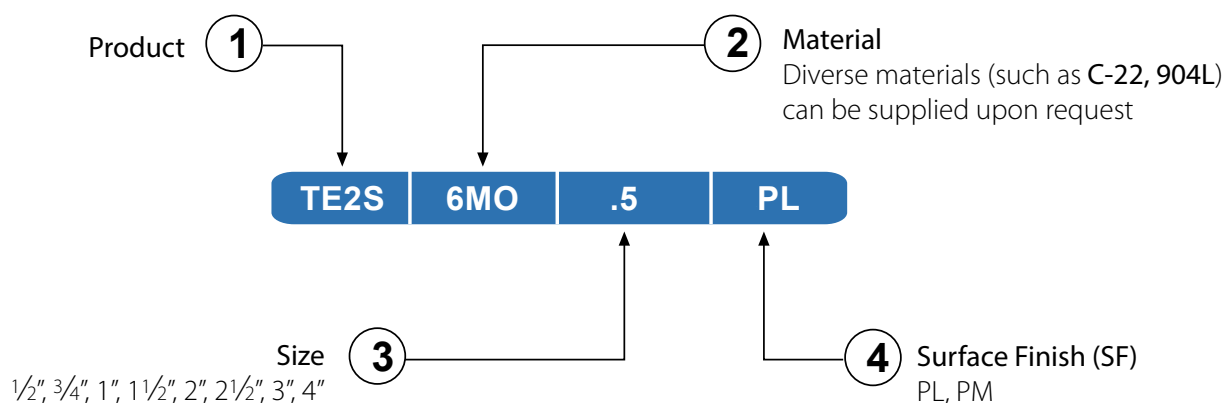

Ordering Information

Description	Product	Material	Size	Wall Thickness*	Surface finish
Tube	TUBE	6Mo	.5	0.065	PL
Weld Insert Ring Hastelloy C-22	RING	C-22	.75	0.065	PM
90° Weld Elbow	TE2S	6Mo	1	0.065	
90° Elbow Clamp One End	TE2C		1.5	0.065	
90° Clamp Elbow	TEG2C		2	0.065	
45° Weld Elbow	TE2KS		2.5	0.065	
45° Elbow Clamp One End	TE2KC		3	0.065	
45° Clamp Elbow	TEG2K		4	0.083	
Tee Equal	TE7WWW				
Short Outlet Tee	TE7WWCS				
Tee Reducing	TE7RWWW				
Short Outlet Reducing Tee	TE7RWWCS				
Instrument Tee	TE7IWWCS				
Short Concentric Reducer	TE31SWW				
Short Eccentric Reducer	TE32SWW				
Short Concentric Reducer Clamp	TEG31SCC				
Short Eccentric Reducer Clamp	TEG32SCC				
Short Concentric Reducer One Clamp	TE31SCW				
Short Eccentric Reducer One Clamp	TE32SCW				
Clamp Ferrule Short	TEG2CS				
Clamp Ferrule Medium	TEG14BM7				
Clamp Ferrule Long	TEG14AM7				
Solid End Cap	TEG16A				

* Refers to Tubes

Tubes

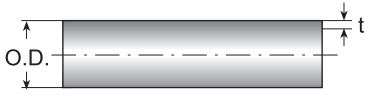

AL-6XN® ALLOY TUBING

Size	Item Number	Wall Thickness
½"	TUBE6MO.5x0.065..	0.065
¾"	TUBE6MO.75x0.065..	0.065
1"	TUBE6MO1.0x0.065..	0.065
1½"	TUBE6MO1.5x0.065..	0.065
2"	TUBE6MO2.0x0.065..	0.065
2½"	TUBE6MO2.5x0.065..	0.065
3"	TUBE6MO3.0x0.065..	0.065
4"	TUBE6MO4.0x0.083..	0.083

Weld Insert Rings



WELD INSERT RING HASTELLOY C-22

Size	Item Number	Material
½"	RINGC22-0.5	C-22
¾"	RINGC22-0.75	C-22
1"	RINGC22-1.0	C-22
1½"	RINGC22-1.5	C-22
2"	RINGC22-2.0	C-22
2½"	RINGC22-2.5	C-22
3"	RINGC22-3.0	C-22
4"	RINGC22-4.0	C-22

Elbows - 90°

TE2S - 90° WELD ELBOW

Size	Dimensions		Item Number
	A in.	A mm	
½"	3.000	76.2	TE2S6MO.5-..
¾"	3.000	76.2	TE2S6MO.75-..
1"	3.000	76.2	TE2S6MO1.0-..
1½"	3.750	95.3	TE2S6MO1.5-..
2"	4.750	120.7	TE2S6MO2.0-..
2½"	5.500	139.7	TE2S6MO2.5-..
3"	6.250	158.8	TE2S6MO3.0-..
4"	8.000	203.2	TE2S6MO4.0-..

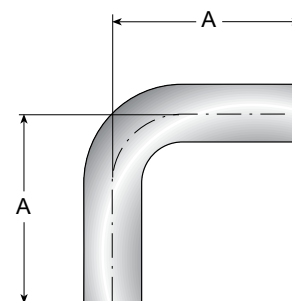

BPE TABLE # DT-4.1.1-1

TE2C - 90° ELBOW CLAMP ONE END

Size	Dimensions				Item Number
	A in.	A mm	B in.	B mm	
½"	3.000	76.2	1.625	41.3	TE2C6MO.5-..
¾"	3.000	76.2	1.625	41.3	TE2C6MO.75-..
1"	3.000	76.2	2.000	50.8	TE2C6MO1.0-..
1½"	3.750	95.3	2.750	69.9	TE2C6MO1.5-..
2"	4.750	120.7	3.500	88.9	TE2C6MO2.0-..
2½"	5.500	139.7	4.250	108.0	TE2C6MO2.5-..
3"	6.250	158.8	5.000	127.0	TE2C6MO3.0-..
4"	8.000	203.2	6.625	168.3	TE2C6MO4.0-..

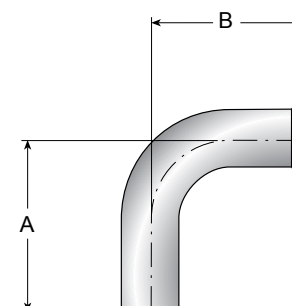

BPE TABLE # DT-4.1.1-2

TEG2C - 90° CLAMP ELBOW

Size	Dimensions		Item Number
	A in.	A mm	
½"	1.625	41.3	TEG2C6MO.5-..
¾"	1.625	41.3	TEG2C6MO.75-..
1"	2.000	50.8	TEG2C6MO1.0-..
1½"	2.750	69.9	TEG2C6MO1.5-..
2"	3.500	88.9	TEG2C6MO2.0-..
2½"	4.250	108.0	TEG2C6MO2.5-..
3"	5.000	127.0	TEG2C6MO3.0-..
4"	6.625	168.3	TEG2C6MO4.0-..

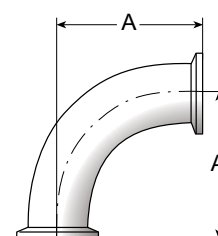

BPE TABLE # DT-4.1.1-3

Note: Available on demand

Elbows - 45°

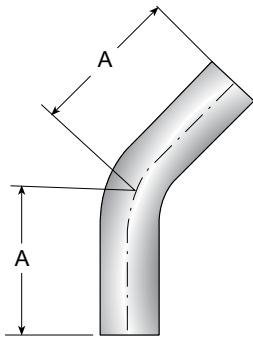

BPE TABLE # DT-4.1.1-4

TE2KS - 45° WELD ELBOW

Size	Dimensions		Item Number
	A in.	A mm	
½"	2.250	57.2	TE2KS6MO.5-..
¾"	2.250	57.2	TE2KS6MO.75-..
1"	2.250	57.2	TE2KS6MO1.0-..
1½"	2.500	63.5	TE2KS6MO1.5-..
2"	3.000	76.2	TE2KS6MO2.0-..
2½"	3.375	85.7	TE2KS6MO2.5-..
3"	3.625	92.1	TE2KS6MO3.0-..
4"	4.500	114.3	TE2KS6MO4.0-..

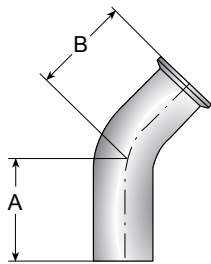

BPE TABLE # DT-4.1.1-5

TE2KC - 45° ELBOW CLAMP ONE END

Size	Dimensions				Item Number
	A in.	A mm	B in.	B mm	
½"	2.250	57.2	1.000	25.4	TE2KC6MO.5-..
¾"	2.250	57.2	1.000	25.4	TE2KC6MO.75-..
1"	2.250	57.2	1.125	28.6	TE2KC6MO1.0-..
1½"	2.500	63.5	1.438	36.5	TE2KC6MO1.5-..
2"	3.000	76.2	1.750	44.5	TE2KC6MO2.0-..
2½"	3.375	85.7	2.063	52.4	TE2KC6MO2.5-..
3"	3.625	92.1	2.375	60.3	TE2KC6MO3.0-..
4"	4.500	114.3	3.125	79.4	TE2KC6MO4.0-..

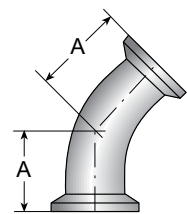

BPE TABLE # DT-4.1.1-6

TEG2K - 45° CLAMP ELBOW

Size	Dimensions		Item Number
	A in.	A mm	
½"	1.000	25.4	TEG2K6MO.5-..
¾"	1.000	25.4	TEG2K6MO.75-..
1"	1.125	28.6	TEG2K6MO1.0-..
1½"	1.438	36.5	TEG2K6MO1.5-..
2"	1.750	44.5	TEG2K6MO2.0-..
2½"	2.063	52.4	TEG2K6MO2.5-..
3"	2.375	60.3	TEG2K6MO3.0-..
4"	3.125	79.4	TEG2K6MO4.0-..

Note: Available on demand

Tees

TE7WWW - EQUAL TEE

Size	Dimensions		Item Number
	A in.	A mm	
½"	1.875	47.6	TE7WWW6MO.5-..
¾"	2.000	50.8	TE7WWW6MO.75-..
1"	2.125	54.0	TE7WWW6MO1.0-..
1½"	2.375	60.3	TE7WWW6MO1.5-..
2"	2.875	73.0	TE7WWW6MO2.0-..
2½"	3.125	79.4	TE7WWW6MO2.5-..
3"	3.375	85.7	TE7WWW6MO3.0-..
4"	4.125	104.8	TE7WWW6MO4.0-..

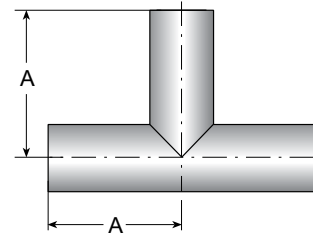

BPE TABLE # DT-4.1.2-1

TE7WWCS - SHORT OUTLET TEE

Size	Dimensions				Item Number
	A in.	A mm	B in.	B mm	
½"	1.875	47.6	1.000	25.4	TE7WWCS6MO.5-..
¾"	2.000	50.8	1.125	28.6	TE7WWCS6MO.75-..
1"	2.125	54.0	1.125	28.6	TE7WWCS6MO1.0-..
1½"	2.375	60.3	1.375	34.9	TE7WWCS6MO1.5-..
2"	2.875	73.0	1.625	41.3	TE7WWCS6MO2.0-..
2½"	3.125	79.4	1.875	47.6	TE7WWCS6MO2.5-..
3"	3.375	85.7	2.125	54.0	TE7WWCS6MO3.0-..
4"	4.125	104.8	2.750	69.9	TE7WWCS6MO4.0-..

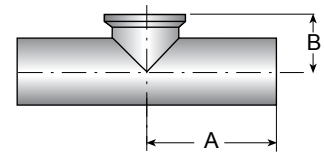

BPE TABLE # DT-4.1.2-2

Tees

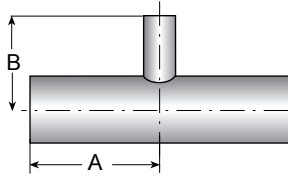

BPE TABLE # DT-4.1.2-6

TE7RWWW - TEE REDUCING

Size	Dimensions				Item Number
	A in.	A mm	B in.	B mm	
¾ x ½	2.000	50.8	2.000	50.8	TE7RWWW6MO.75x.5-..
1 x ½	2.125	54.0	2.125	54.0	TE7RWWW6MO1.0x.5-..
1 x ¾	2.125	54.0	2.125	54.0	TE7RWWW6MO1.0x.75-..
1½ x ½	2.375	60.3	2.375	60.3	TE7RWWW6MO1.5x.5-..
1½ x ¾	2.375	60.3	2.375	60.3	TE7RWWW6MO1.5x.75-..
1½ x 1	2.375	60.3	2.375	60.3	TE7RWWW6MO1.5x1.0-..
2 x ½	2.875	73.0	2.625	66.7	TE7RWWW6MO2.0x.5-..
2 x ¾	2.875	73.0	2.625	66.7	TE7RWWW6MO2.0x.75-..
2 x 1	2.875	73.0	2.625	66.7	TE7RWWW6MO2.0x1.0-..
2 x 1½	2.875	73.0	2.625	66.7	TE7RWWW6MO2.0x1.5-..
2½ x 1	3.125	79.4	2.875	73.0	TE7RWWW6MO2.5x1.0-..
2½ x 1½	3.125	79.4	2.875	73.0	TE7RWWW6MO2.5x1.5-..
2½ x 2	3.125	79.4	2.875	73.0	TE7RWWW6MO2.5x2.0-..
3 x ½	3.375	85.7	3.125	79.4	TE7RWWW6MO3.0x.5-..
3 x ¾	3.375	85.7	3.125	79.4	TE7RWWW6MO3.0x.75-..
3 x 1	3.375	85.7	3.125	79.4	TE7RWWW6MO3.0x1.0-..
3 x 1½	3.375	85.7	3.125	79.4	TE7RWWW6MO3.0x1.5-..
3 x 2	3.375	85.7	3.125	79.4	TE7RWWW6MO3.0x2.0-..
3 x 2½	3.375	85.7	3.125	79.4	TE7RWWW6MO3.0x2.5-..
4 x 1	4.125	104.8	3.625	92.1	TE7RWWW6MO4.0x1.0-..
4 x 1½	4.125	104.8	3.625	92.1	TE7RWWW6MO4.0x1.5-..
4 x 2	4.125	104.8	3.875	98.4	TE7RWWW6MO4.0x2.0-..
4 x 3	4.125	104.8	3.875	98.4	TE7RWWW6MO4.0x3.0-..

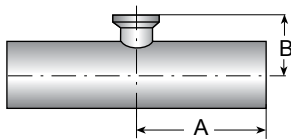

BPE TABLE # DT-4.1.2-7

TE7RWWCS - SHORT OUTLET REDUCING TEE

Size	Dimensions				Item Number
	A in.	A mm	B in.	B mm	
¾ x ½	2.000	50.8	1.000	25.4	TE7RWWCS6MO.75x.5-..
1 x ½	2.125	54.0	1.125	28.6	TE7RWWCS6MO1.0x.5-..
1 x ¾	2.125	54.0	1.125	28.6	TE7RWWCS6MO1.0x.75-..
1½ x ½	2.375	60.3	1.375	34.9	TE7RWWCS6MO1.5x.5-..
1½ x ¾	2.375	60.3	1.375	34.9	TE7RWWCS6MO1.5x.75-..
1½ x 1	2.375	60.3	1.375	34.9	TE7RWWCS6MO1.5x1.0-..
2 x ½	2.875	73.0	1.625	41.3	TE7RWWCS6MO2.0x.5-..
2 x ¾	2.875	73.0	1.625	41.3	TE7RWWCS6MO2.0x.75-..
2 x 1	2.875	73.0	1.625	41.3	TE7RWWCS6MO2.0x1.0-..
2 x 1½	2.875	73.0	1.625	41.3	TE7RWWCS6MO2.0x1.5-..
2½ x 1	3.125	79.4	1.875	47.6	TE7RWWCS6MO2.5x1.0-..
2½ x 1½	3.125	79.4	1.875	47.6	TE7RWWCS6MO2.5x1.5-..
2½ x 2	3.125	79.4	1.875	47.6	TE7RWWCS6MO2.5x2.0-..
3 x ½	3.375	85.7	2.125	54.0	TE7RWWCS6MO3.0x.5-..
3 x ¾	3.375	85.7	2.125	54.0	TE7RWWCS6MO3.0x.75-..
3 x 1	3.375	85.7	2.125	54.0	TE7RWWCS6MO3.0x1.0-..
3 x 1½	3.375	85.7	2.125	54.0	TE7RWWCS6MO3.0x1.5-..
3 x 2	3.375	85.7	2.125	54.0	TE7RWWCS6MO3.0x2.0-..
4 x ½	4.125	104.8	2.625	66.7	TE7RWWCS6MO4.0x.5-..
4 x ¾	4.125	104.8	2.625	66.7	TE7RWWCS6MO4.0x.75-..
4 x 1	4.125	104.8	2.625	66.7	TE7RWWCS6MO4.0x1.0-..
4 x 1½	4.125	104.8	2.625	66.7	TE7RWWCS6MO4.0x1.5-..
4 x 2	4.125	104.8	2.625	66.7	TE7RWWCS6MO4.0x2.0-..
4 x 2½	4.125	104.8	2.625	66.7	TE7RWWCS6MO4.0x2.5-..
4 x 3	4.125	104.8	2.625	66.7	TE7RWWCS6MO4.0x3.0-..

Tees

TE7IWWCS - INSTRUMENT TEE

Size	Dimensions				Item Number
	A in.	A mm	B in.	B mm	
½ x 1½	2.500	63.5	0.875	22.2	TE7IWWCS6MO.5x1.5-..
½ x 2	2.500	63.5	1.000	25.4	TE7IWWCS6MO.5x2.0-..
¾ x 1½	2.500	63.5	1.125	28.6	TE7IWWCS6MO.75x1.5-..
¾ x 2	2.750	69.9	1.000	25.4	TE7IWWCS6MO.75x2.0-..
1 x 1½	2.750	69.9	1.125	28.6	TE7IWWCS6MO1.0x1.5-..
1 x 2	2.750	69.9	1.250	31.8	TE7IWWCS6MO1.0x2.0-..
1½ x 2	2.750	69.9	1.500	38.1	TE7IWWCS6MO1.5x2.0-..

Note: Available on demand

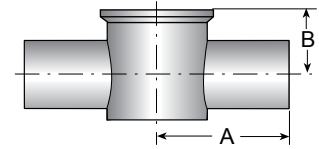

BPE TABLE # DT-4.1.2-10



Reducers

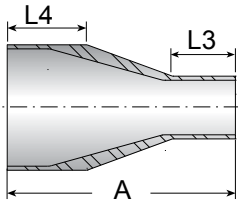

BPE TABLE # DT-4.1.3-1

TE31SWW - SHORT CONCENTRIC REDUCER

Size	Dimensions						Item Number
	A In.	A mm.	L3 In.	L3 mm.	L4 In.	L4 mm.	
3/4 x 1/2	2.125	53.975	1.000	25.4	1.000	25.4	TE31SWW6MO.75x.5-..
1 x 1/2	2.500	63.5	1.000	25.4	1.000	25.4	TE31SWW6MO1.0x.5-..
1 x 3/4	2.125	53.975	1.000	25.4	1.000	25.4	TE31SWW6MO1.0x.75-..
1 1/2 x 3/4	3.000	76.2	1.000	25.4	1.000	25.4	TE31SWW6MO1.5x.75-..
1 1/2 x 1	2.500	63.5	1.000	25.4	1.000	25.4	TE31SWW6MO1.5x1.0-..
2 x 1	3.375	85.725	1.000	25.4	1.000	25.4	TE31SWW6MO2.0x1.0-..
2 x 1 1/2	2.500	63.5	1.000	25.4	1.000	25.4	TE31SWW6MO2.0x1.5-..
2 1/2 x 1 1/2	3.375	85.725	1.000	25.4	1.000	25.4	TE31SWW6MO2.5x1.5-..
2 1/2 x 2	2.500	63.5	1.000	25.4	1.000	25.4	TE31SWW6MO2.5x2.0..
3 x 1 1/2	4.250	107.95	1.000	25.4	1.500	38.1	TE31SWW6MO3.0x1.5-..
3 x 2	3.375	85.725	1.000	25.4	1.500	38.1	TE31SWW6MO3.0x2.0-..
3 x 2 1/2	2.625	66.675	1.000	25.4	1.500	38.1	TE31SWW6MO3.0x2.5-..
4 x 2	5.125	130.175	1.000	25.4	1.500	38.1	TE31SWW6MO4.0x2.0-..
4 x 2 1/2	4.250	107.95	1.000	25.4	1.500	38.1	TE31SWW6MO4.0x2.5-..
4 x 3	3.875	98.425	1.500	38.1	1.500	38.1	TE31SWW6MO4.0x3.0-..

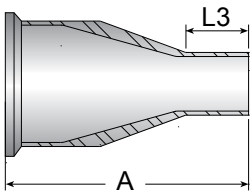

BPE TABLE # DT-4.1.3-2

TE31SCW - SHORT CONCENTRIC REDUCER ONE CLAMP

Size	Dimensions				Item Number
	A In.	A mm.	L3 In.	L3 mm.	
3/4 x 1/2	2.625	66.675	1.000	25.4	TE31SCW6MO.75x.5-..
1 x 1/2	3.000	76.2	1.000	25.4	TE31SCW6MO1.0x.5-..
1 x 3/4	2.625	66.675	1.000	25.4	TE31SCW6MO1.0x.75-..
1 1/2 x 3/4	3.500	88.9	1.000	25.4	TE31SCW6MO1.5x.75-..
1 1/2 x 1	3.000	76.2	1.000	25.4	TE31SCW6MO1.5x1.0-..
2 x 1	3.875	98.425	1.000	25.4	TE31SCW6MO2.0x1.0-..
2 x 1 1/2	3.000	76.2	1.000	25.4	TE31SCW6MO2.0x1.5-..
2 1/2 x 1 1/2	3.875	98.425	1.000	25.4	TE31SCW6MO2.5x1.5-..
2 1/2 x 2	3.000	76.2	1.000	25.4	TE31SCW6MO2.5x2.0..
3 x 2	3.875	98.425	1.000	25.4	TE31SCW6MO3.0x2.0-..
3 x 2 1/2	3.125	79.375	1.000	25.4	TE31SCW6MO3.0x2.5-..
4 x 2 1/2	4.875	123.825	1.000	25.4	TE31SCW6MO4.0x2.5-..
4 x 3	4.500	114.3	1.500	38.1	TE31SCW6MO4.0x3.0-..

Note: Available on demand

Reducers

TEG31SCC - SHORT CONCENTRIC REDUCER CLAMP

Size	Dimensions		Item Number
	A In.	A mm.	
¾ x ½	3.125	79.375	TEG31SCC6MO.75x.5-..
1 x ½	3.500	88.9	TEG31SCC6MO1.0x.5-..
1 x ¾	3.125	79.375	TEG31SCC6MO1.0x.75-..
1½ x ½	4.000	101.6	TEG31SCC6MO1.5x.5-..
1½ x ¾	3.500	88.9	TEG31SCC6MO1.5x.75-..
1½ x 1	4.375	111.125	TEG31SCC6MO1.5x1.0-..
2 x 1	3.500	88.9	TEG31SCC6MO2.0x1.0-..
2 x 1½	4.375	111.125	TEG31SCC6MO2.0x1.5-..
2½ x 2	3.500	88.9	TEG31SCC6MO2.5x2.0-..
3 x 1½	5.250	133.35	TEG31SCC6MO3.0x1.5-..
3 x 2	4.375	111.125	TEG31SCC6MO3.0x2.0-..
3 x 2½	3.625	92.075	TEG31SCC6MO3.0x2.5-..
4 x 3	5.000	127	TEG31SCC6MO4.0x3.0-..

Note: Available on demand

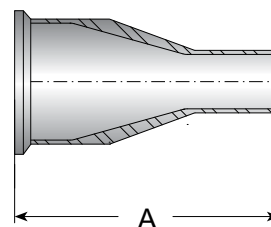

BPE TABLE # DT-4.1.3-3

TE32SWW - SHORT ECCENTRIC REDUCER

Size	Dimensions						Item Number
	A In.	A mm.	L3 In.	L3 mm.	L4 In.	L4 mm.	
¾ x ½	2.125	53.975	1.000	25.4	1.000	25.4	TE32SWW6MO.75x.5-..
1 x ½	2.500	63.5	1.000	25.4	1.000	25.4	TE32SWW6MO1.0x.5-..
1 x ¾	2.125	53.975	1.000	25.4	1.000	25.4	TE32SWW6MO1.0x.75-..
1½ x ¾	3.000	76.2	1.000	25.4	1.000	25.4	TE32SWW6MO1.5x.75-..
1½ x 1	2.500	63.5	1.000	25.4	1.000	25.4	TE32SWW6MO1.5x1.0-..
2 x 1	3.375	85.725	1.000	25.4	1.000	25.4	TE32SWW6MO2.0x1.0-..
2 x 1½	2.500	63.5	1.000	25.4	1.000	25.4	TE32SWW6MO2.0x1.5-..
2½ x 1½	3.375	85.725	1.000	25.4	1.000	25.4	TE32SWW6MO2.5x1.5-..
2½ x 2	2.500	63.5	1.000	25.4	1.000	25.4	TE32SWW6MO2.5x2.0-..
3 x 1½	4.250	107.95	1.000	25.4	1.500	38.1	TE32SWW6MO3.0x1.5-..
3 x 2	3.375	85.725	1.000	25.4	1.500	38.1	TE32SWW6MO3.0x2.0-..
3 x 2½	2.625	66.675	1.000	25.4	1.500	38.1	TE32SWW6MO3.0x2.5-..
4 x 2	5.125	130.175	1.000	25.4	1.500	38.1	TE32SWW6MO4.0x2.0-..
4 x 2½	4.250	107.95	1.000	25.4	1.500	38.1	TE32SWW6MO4.0x2.5-..
4 x 3	3.875	98.425	1.500	38.1	1.500	38.1	TE32SWW6MO4.0x3.0-..

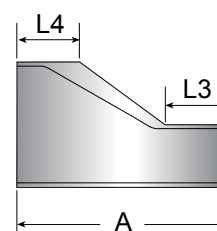

BPE TABLE # DT-4.1.3-1

Reducers

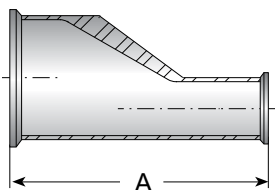

BPE TABLE # DT-4.1.3-3

TEG32SCC - SHORT ECCENTRIC REDUCER CLAMP

Size	Dimensions		Item Number
	A In.	A mm.	
¾ x ½	3.125	79.375	TEG32SCC6MO.75x.5-..
1 x ½	3.500	88.9	TEG32SCC6MO1.0x.5-..
1 x ¾	3.125	79.375	TEG32SCC6MO1.0x.75-..
1½ x ¾	4.000	101.6	TEG32SCC6MO1.5x.75-..
1½ x 1	3.500	88.9	TEG32SCC6MO1.5x1.0-..
2 x 1	4.375	111.125	TEG32SCC6MO2.0x1.0-..
2 x 1½	3.500	88.9	TEG32SCC6MO2.0x1.5-..
3 x 2	4.375	111.125	TEG32SCC6MO3.0x2.0-..
3 x 2½	3.625	92.075	TEG32SCC6MO3.0x2.5-..
4 x 2	6.250	158.75	TEG32SCC6MO4.0x2.0-..
4 x 3	5.000	127	TEG32SCC6MO4.0x3.0-..

Note: Available on demand

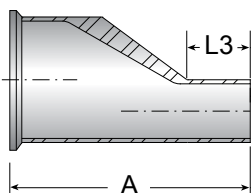

BPE TABLE # DT-4.1.3-2

TE32SCW - SHORT ECCENTRIC REDUCER ONE CLAMP

Size	Dimensions				Item Number
	A In.	A mm.	L3 In.	L3 mm.	
¾ x ½	2.625	66.675	1.000	25.4	TE32SCW6MO.75x.5-..
1 x ½	3.000	76.2	1.000	25.4	TE32SCW6MO1.0x.5-..
1 x ¾	2.625	66.675	1.000	25.4	TE32SCW6MO1.0x.75-..
1½ x ¾	3.500	88.9	1.000	25.4	TE32SCW6MO1.5x.75-..
1½ x 1	3.000	76.2	1.000	25.4	TE32SCW6MO1.5x1.0-..
2 x 1	3.875	98.425	1.000	25.4	TE32SCW6MO2.0x1.0-..
2 x 1½	3.000	76.2	1.000	25.4	TE32SCW6MO2.0x1.5-..
2½ x 1½	3.875	98.425	1.000	25.4	TE32SCW6MO2.5x1.5-..
2½ x 2	3.000	76.2	1.000	25.4	TE32SCW6MO2.5x2.0-..
3 x 2	3.875	98.425	1.000	25.4	TE32SCW6MO3.0x2.0-..
3 x 2½	3.125	79.375	1.000	25.4	TE32SCW6MO3.0x2.5-..
4 x 2	5.750	146.05	1.000	25.4	TE32SCW6MO4.0x2.0-..
4 x 3	4.500	114.3	1.500	38.1	TE32SCW6MO4.0x3.0-..

Note: Available on demand

Ferrules

TEG14AM7 - CLAMP FERRULE LONG

Size	Dimensions				Item Number
	A in.	A mm	D in.	D mm	
1/2"	0.500	12.7	0.984	24.9	TEG14AM76MO.5-..
3/4"	0.500	12.7	0.984	24.9	TEG14AM76MO.75-..
1"	0.500	12.7	1.984	50.3	TEG14AM76MO1.0-..
1 1/2"	0.500	12.7	1.984	50.3	TEG14AM76MO1.5-..
2"	0.500	12.7	2.516	63.9	TEG14AM76MO2.0-..
2 1/2"	0.500	12.7	3.047	77.3	TEG14AM76MO2.5-..
3"	0.500	12.7	3.579	90.9	TEG14AM76MO3.0-..
4"	0.625	15.9	4.682	118.9	TEG14AM76MO4.0-..

Note: Available on demand

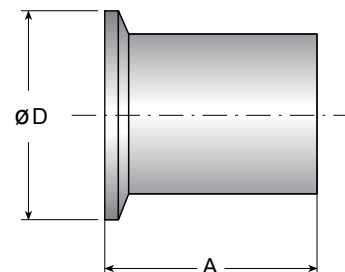

BPE TABLE # DT-4.1.4-1(A)

TEG14BM7 - CLAMP FERRULE MEDIUM

Size	Dimensions				Item Number
	A in.	A mm	D in.	D mm	
1/2"	1.130	28.7	0.984	24.9	TEG14BM76MO.5-..
3/4"	1.130	28.7	0.984	24.9	TEG14BM76MO.75-..
1"	1.130	28.7	1.984	50.3	TEG14BM76MO1.0-..
1 1/2"	1.130	28.7	1.984	50.3	TEG14BM76MO1.5-..
2"	1.130	28.7	2.516	63.9	TEG14BM76MO2.0-..
2 1/2"	1.130	28.7	3.047	77.3	TEG14BM76MO2.5-..
3"	1.130	28.7	3.579	90.9	TEG14BM76MO3.0-..
4"	1.130	28.7	4.682	118.9	TEG14BM76MO4.0-..

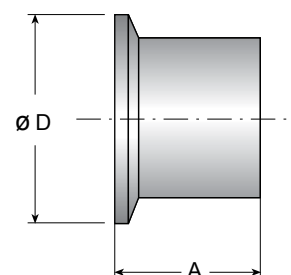

BPE TABLE # DT-4.1.4-1(B)

TEG2CS - CLAMP FERRULE SHORT

Size	Dimensions				Item Number
	A in.	A mm	D in.	D mm	
1/2"	1.750	44.5	0.984	24.9	TEG2CS6MO.5-..
3/4"	1.750	44.5	0.984	24.9	TEG2CS6MO.75-..
1"	1.750	44.5	1.984	50.3	TEG2CS6MO1.0-..
1 1/2"	1.750	44.5	1.984	50.3	TEG2CS6MO1.5-..
2"	2.250	57.2	2.516	63.9	TEG2CS6MO2.0-..
2 1/2"	2.250	57.2	3.047	77.3	TEG2CS6MO2.5-..
3"	2.250	57.2	3.579	90.9	TEG2CS6MO3.0-..
4"	2.250	57.2	4.682	118.9	TEG2CS6MO4.0-..

Note: Available on demand

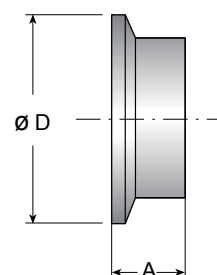

BPE TABLE # DT-4.1.4-1(C)

Solid End Caps

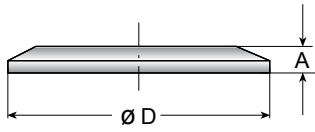

BPE TABLE # DT-4.1.5-2

TEG16A - SOLID END CAP

Size	Dimensions				Item Number
	A in.	A mm	D in.	D mm	
1/2" - 3/4"	0.187	4.7	0.984	24.9	TEG16A6MO.75-..
1" - 1 1/2"	0.250	6.4	1.984	50.3	TEG16A6MO1.5-..
2"	0.250	6.4	2.516	63.9	TEG16A6MO2.0-..
2 1/2"	0.250	6.4	3.047	77.3	TEG16A6MO2.5-..
3"	0.250	6.4	3.579	90.9	TEG16A6MO3.0-..
4"	0.312	7.9	4.682	118.9	TEG16A6MO4.0-..



Standard Specifications

The American Society of Mechanical Engineers (ASME) and the American Society for Testing and Materials (ASTM) specifications for the wide range of AL-6XN® alloy forms are listed in Table 2.

AL-6XN® alloy is approved for ASME Boiler and Pressure Vessel Code construction (Section VIII Div. 1) as Code Case 1997.

Table 2: ASME & ASTM Specifications (UNS N08367)

Product	Specifications	
	ASME	ASTM
Plate, Sheet & Strip	SA 240	A 240
	SB-688	B 688
Rod, Bar & Wire	SB-691	B 691
Welded Pipe	SB-675	B 675
Heat Exchanger Tubing	SA-249	A 249
Sanitary Tubing		A 270
Welded Tube (General Applications)	SB-676	B 676
		A 269
Seamless Pipe & Tube	SB-690	B 690
Billets and Bars for Reforging		B 472
Forged Pipe Flanges, Fittings & Valves	SB-462	B 462
Wrought Nickel Alloy Welded Fittings	SB-366	B 366
Nickel Alloy Forgings	SB-564	B 564
Pipe Welded w/ Filler	SB-804	B 804
Castings (CN-3MN, UNS J94651)	SA-351	A 743
		A 744

Source: ATI Allegheny Ludlum

Physical Properties

The physical properties of the AL-6XN® alloy are similar to those of other austenitic stainless steels (Table 3). The elastic modulus values of AL-6XN® alloy are lower than those for Type 316L and Alloy 625. However, these modulus values are high in comparison to other non-ferrous alloys, such as titanium.

The thermal conductivity and coefficient of expansion values are lower than those for Type 316L but are higher than Alloy 625.

Table 3: Comparison of physical properties

Alloy	Elastic Modulus		Thermal Conductivity at 212°F		Expansion Coefficient From 77 to 212°F	
	psi x 10 ⁶	Gpa	Btu / hr • ft • °F	W / (m • K)	10 ⁶ /°F	10 ⁶ /°C
Type 316L	29.0	200	9.2	16.0	8.5	15.3
AL-6XN®	28.3	195	7.5	13.0	7.9	14.2
Alloy 904L	28.3	195	7.6	13.2	8.3	15.0
Alloy 625	29.7	205	6.2	10.7	7.1	12.8
Nickel 200	30.0	207	38.8	67.1	7.4	13.4
C-276	29.8	205	6.4	9.9	6.2	11.2
C-22®	29.9	206	6.4	11.1	6.9	12.4
Titanium	15.0	103	9.5	16.4	5.0	9.1

AL-6XN® alloy has a stable face-centered cubic crystal structure similar to other austenitic stainless alloys. The AL-6XN® alloy is non-magnetic. Its magnetic permeability remains low even after severe cold forming. Typical physical properties of AL-6XN® alloy are presented in Table 4.

Table 4: Physical Properties of AL-6XN® Alloy at Room Temperature

Property	Value	Units
Density	0.291	lb/in ³
	8.06	g/cm ³
Modulus of Elasticity	28.3 x 10 ⁶	psi
	195	GPa
Melting Range	2410 to 2550	°F
	1320 to 1400	°C
Thermal Conductivity		
68 to 212°F	7.5	Btu / hr • ft • °F
20 to 100°C	14.1	W / (m • K)
Coefficient of Expansion		
68 to 212°F	7.9	10 ⁶ / °F
20 to 100°C	14.2	10 ⁶ / °C
Specific Heat capacity		
	0.11	Btu / lb • °F
	500	J/kg • K
Electrical Resistivity		
	535	Ohm • circ mil / ft
	0.89	Ωm
Scaling temperature		
	1885	°F
	1030	°C

Source: ATI Allegheny Ludlum

Mechanical Properties (Annealed Condition)

In comparison to more conventional austenitic stainless steels, the AL-6XN® alloy is much stronger with comparable ductility. Table 5 shows typical transverse tensile properties at room temperature for AL-6XN® sheet 0.026 to 0.139 inches (0.66 to 3.53 mm) thick in comparison to other austenitic stainless flat rolled products.

Table 5: Typical tensile properties for austenitic stainless alloy sheet

Properties at Room Temperature	Type 316	Alloy 904L	AL-6XN® Alloy
Yield strength, ksi (MPa)	45	42	53
(0.2% Offset)	(310)	(290)	(365)
Ultimate Tensile Strength ksi (MPa)	88	86	108
	(607)	(593)	(744)
% Elongation in 2" (51 mm)	57	43	47
Hardness Rockwell B (Rock well 30T)	81	79	88
	(65)	(63)	(73)

Material Technical Information

Table 6: shows AL-6XN[®] alloy (UNS N08367) Modulus of Elasticity in Tension.

Temp °F	Temp °C	Modulus 10 ⁶ psi	Modulus MPa
75	24	28.3	195
200	93	27.4	189
400	204	26.1	180
600	316	24.8	171
800	427	23.4	161
1000	538	22.1	152

Source: ATI Allegheny Ludlum

The hardness of the alloy is relatively high (typically 88 RB) and the alloy work hardens in a manner similar to other stable austenitic stainless steels (Figure 1).

Figure 1: Effect of cold work on the tensile properties of the AL-6XN[®] alloy.

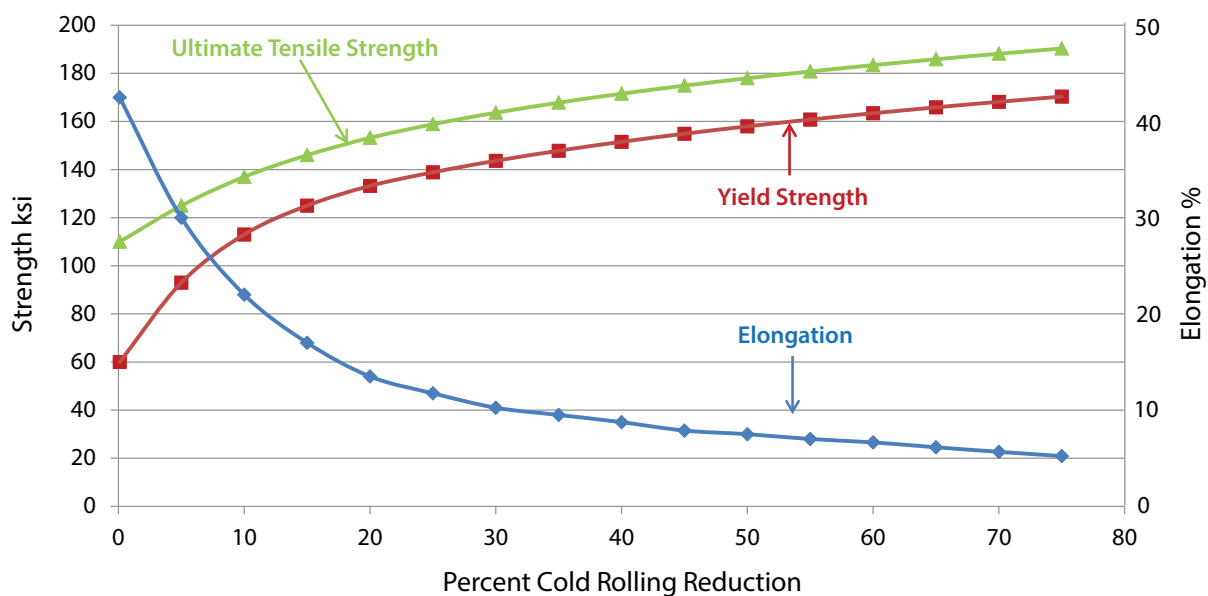

Source: ATI Allegheny Ludlum

Working Conditions

Forming

Hot Forming

Hot-forming operations on AL-6XN[®] alloy, including hot rolling, are generally performed in the temperature range of 1830-2300°F (1000-1260°C). Hot workability is actually reduced at higher temperatures and secondary phase precipitation can occur at lower temperatures. Secondary phases can be dissolved by subsequent heat treatment above 2025°F (1110°C) followed by rapid cooling. If the cooling rate is too slow, the alloy will be less resistant to corrosion.

Regardless of the thermal treatment, a heavy, tenacious surface scale will form when the alloy is heat treated in air at temperatures above 1885°F (1030°C).

The formation of the oxide and the associated chromium depletion of the base metal can have a detrimental effect on corrosion resistance. Such scales and depleted surfaces must be removed.

Warm Forming

Dishing and flanging operations are eased by preheating at or below 600°F (315°C). This may facilitate the deformation involved in forming pieces.

No significant reduction in strength or improvement in ductility occurs at temperatures in the range 600 to 1000°F (315 to 540°C). In all cases, warm-forming operations should be kept under 1000°F (540°C) to avoid precipitation of deleterious phases.

Cold Forming

AL-6XN[®] alloy is very strong yet it can be easily cold formed much like other austenitic stainless steels. Operations such as bending, drawing and pressing can be readily performed even when the alloy is cold.

The high strength of the alloy means that additional pressure will be required for hold-down and forming relative to that for other 300 series stainless steels. Plate can normally be press-brake bent over a radius equal to the plate thickness. As with other austenitic stainless and nickel alloys, bending AL-6XN[®] alloy over a sharp male die may cause the material to rupture in a ductile manner. Preheating prior to deformation is suggested when the high strength of AL-6XN[®] alloy may exceed the capabilities of the forming press. Heat treatment after cold working is usually not required. The austenitic structure of the alloy is very stable and does not transform to martensite even under extensive forming.



Machinability

Satisfactory machinability may be achieved by selecting the correct tools and machine set-ups. The relatively high hardness (typically 88 RB) of the AL-6XN® alloy must be taken into account when planning machining operations. Machining guidelines are given in Table 7.

The following suggestions may also be useful:

- Chips of austenitic stainless steel tend to be stringy and ductile so that the use of curlers or breakers is suggested for turning operations
- Machine tools should not be used at more than 75% of rated capacity
- Both tool and workpiece should be rigid with minimum overhang
- Tools should be reground at regular intervals to keep them sharp
- Feed rate should be high enough to ensure that the tool cutting edge is getting under the previous cut thus avoiding work-hardened zones
- The tool should not ride on the workpiece as this will work harden the material and result in early tool dulling or breakage
- Heavy cuts will require slower speeds and the use of a lubricant is suggested
- Lubricants such as sulfur-chlorinated petroleum oil are suggested

Table 7: Guidelines for machining AL-6XN® Alloy

Operation	Parameter	Value	Feed SFPM	Rate IPR
Turning	-	-	47 - 70	0.001
Cut-off	Tool Width	0.0625 - 0.5 inch	47 - 70	0.001
Forming	Tool Width	1.0 - 1.5 inch	47 - 70	0.001
Drilling	Diameter	0.25 inch	42 - 51	0.006
		0.75 inch	42 - 51	0.014
Reaming	Diameter	Under 0.5 inch	60	0.003
		Over 0.5 inch	60	0.008
Die Threading	Threads (Teeth) per inch	3 - 7.5	4 - 8	-
		8 - 15	6 - 10	-
		Over 16	8 - 12	-
Tapping	-	-	20	-
Milling End Oeripheral	Depth of Cut	0.050 inch	70	0.001 - 0.004
Broaching	Chip Load	0.003 inch / tooth	15	-

Operation	Parameter	Value	Feed SFPM	Rate IPR
Sawing	Under 0.75 inch	10	70	0.005
	0.75 - 2	6	70	0.005
	Over 2	4	70	0.005

Cutting

AL-6XN® plate may be wet or dry abrasive sawed, sheared, laser cut or plasma-arc cut. Shears rated for 3/8 inch (9.5 mm) and mild steel are used to cut up to 1/4 inch (6.4 mm) thick plate. However, the AL-6XN® alloy and other austenitic grades are quite ductile in the annealed condition but work harden more rapidly and require more power and time to cut by sawing than plain carbon steels.

Like other stainless steels and nickel-chromium alloys, the properties of AL-6XN® alloy can be degraded by carbon introduced during oxyacetylene or carbon-arc cutting.

Welding

AL-6XN® alloy is easily welded using similar weld techniques and equipment as 316L stainless steel, including travel speed and weld current.

The acceptable arc-welding processes for fabricating corrosion resistant piping and equipment from AL-6XN® are:

- GTAW - Gas Tungsten Arc Welding
- GMAW - Gas Metal Arc Welding
- SMAW - Shielded Metal Arc Welding
- FCAW - Flux Cored Arc Welding
- SAW - Submerged Arc Welding.
- Autogenous Welding

It is highly recommended to use weld insert rings for additional alloying when orbital or manual welding in the field. The insert ring alloy must have higher molybdenum content than the AL-6XN® alloy to compensate for alloy dilution on cooling.

The choice of the best filler for AL-6XN® alloy depends on the service environment and the fabrication situation. Typically Hastelloy® C-22® (13% Mo) is used, but if C-22® is not available, Alloy 625 (9% Mo) or Alloy C-276 (15% Mo) may be substituted.

This level of molybdenum enrichment provides little margin for dilution of the filler by the base metal.

The desired pitting corrosion resistance of weldments of AL-6XN® alloy can be achieved by selecting filler metals having Pitting Resistance Equivalent Number (PREN) values at least ten times higher than the base metal regardless of the type of arc welding process (see Figure 2). The higher the number, the better the corrosion resistance.

$$PREN = \% Cr + 3.3\% Mo + 30\% N$$

If these filler metals are used, the weldment will have pitting and crevice corrosion resistance about equal to that of the parent metal.

Figure 2: PREN - Pitting Resistance Equivalent Number

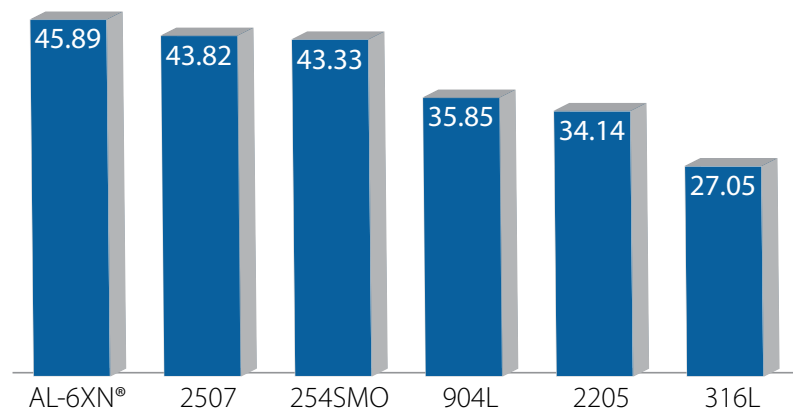

General Technical Information

Pressure service ratings for sanitary stainless steel clamps

Size Tube OD	13MHHM(-H)				13MHHS				13MHP			
	@70°F / 21°C		@250°F / 121°C		@70°F / 21°C		@250°F / 121°C		@70°F / 21°C		@250°F / 121°C	
	PSI	bar	PSI	bar	PSI	bar	PSI	bar	PSI	bar	PSI	bar
1/2 & 3/4"	1500	103	1200	83	-	-	-	-	1500	103	1200	83
1 & 1 1/2"	500	34	250	17	600	41	300	21	1500	103	1200	83
2"	450	31	250	17	550	38	275	19	1000	69	800	55
2 1/2"	400	28	200	14	450	31	225	16	1000	69	800	55
3"	350	24	150	10	350	24	160	11	1000	69	800	55
4"	200	14	125	9	250	17	150	10	1000	69	800	55
5"	175	12	100	7	-	-	-	-	-	-	-	-
6"	150	10	75	5	-	-	-	-	-	-	-	-
8"	100	7	50	3	-	-	-	-	-	-	-	-
10"	40	3	30	2	-	-	-	-	-	-	-	-
12"	30	2	25	2	-	-	-	-	-	-	-	-

Note: The pressure information doesn't refer to the gaskets.

Gasket Material Properties

Property	PTFE®	VITON®	SILICON	EPDM
Temperature Range	-40 to 450° F -40 to 232° C	-20 to 400° F -29 to 204° C	-80 to 450° F -62 to 232° C	-55 to 275° F -48 to 135° C
Acid Resistance	Excellent	Good	Good	Good - excellent
Alkali Resistance	Excellent	Poor - good	Poor - fair	Good - excellent
Abrasion Resistance	Excellent	Good	Good - excellent	Good - excellent
Compression Set	Cold flows	Good - excellent	Good - excellent	Fair

Conversion Table Of Surface Finishes

Mechanical Finish		
μ-in.	μm	Grit
32 Ra	0.8 Ra	150
24 Ra	0.6 Ra	180
20 Ra	0.5 Ra	240
12 Ra	0.3 Ra	320

Available on Demand in Super Austenitic Alloys

Bio-Connect



Connect S



Ball Valves



Single Seat Valves



Double Seat Valves



Butterfly Valves



Check Valves



Diaphragm Valves



Sampling Valves



Specials



MTR - Material Test Report

The MTR is the reference document for the entire history of the production processes and the raw materials used to make the MaxPure 6Mo component.

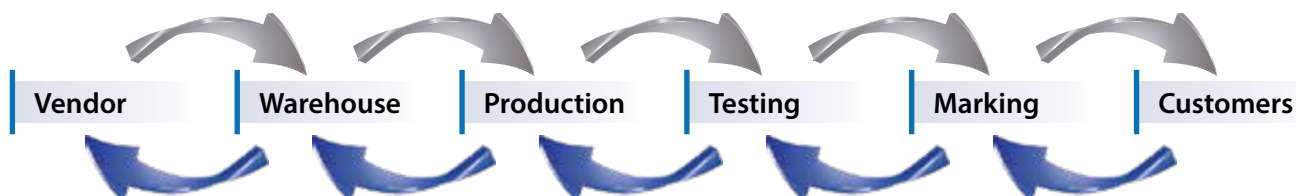

The MTR document is easily generated on-line via www.MaxPure.net using only the job number as input.

The job number is the product identification number which represents all processes and raw materials related to the specific item.

On-Line MTR

Please, enter job/certificate number:

[CREATE CERTIFICATE >](#)



The MTR is also available for download with QR CODE

The MTR format provides the following information:

- Part number, part description and job number
- Material type
- Heat Number per each component describing the fitting and its associated properties:
 - Tube dimensions and standards
 - Chemical composition
 - Mechanical properties
 - Visual, dimensional, corrosion, EDDY current testing, flaring and flattening, PMI Test
- Certificate of Compliance

ASME BPE - Certificate

The American Society of Mechanical Engineers



BPE

CERTIFICATE OF AUTHORIZATION

The named company is authorized by the American Society of Mechanical Engineers (ASME) for the scope shown below in accordance with the applicable rules of the ASME BPE Standard on Bioprocessing Equipment. The use of the certification mark and the authority granted by this Certificate of Authorization are subject to the provisions of the agreement set forth in the application. Any component certified under this authorization shall have been produced, assembled, and tested in accordance with the provisions of the aforementioned ASME standard.

COMPANY:

**EGMO Ltd.
MaxPure
1 Hayotsrim St.
Nahariya 22110
Israel**

SCOPE:

Manufacture of ferrous and nonferrous fittings at the above location only

AUTHORIZED: **May 1, 2018**
EXPIRES: **May 21, 2023**
CERTIFICATE NUMBER: **BPE-102**

Vice President, Conformity Assessment

Managing Director, Conformity Assessment



NEUMO EHRENBERG GROUP

GLOBAL LOCATIONS



NEUMO GmbH+Co. KG (D)
 Tel: +49 (0) 7043 36 0
 Fax: +49 (0) 7043 36 179
 E-Mail: info@neumo.de
 www.neumo.de
GERMANY



VNE Corporation
 Tel: +1 800 356 1111
 +1 608 756 4930
 Fax: +1 608 756 3643
 E-Mail: stainless@vnecorp.com
 www.vnestainless.com
U.S.A



EGMO Ltd.
 Tel: +972 (0) 4 9855 176
 +972 (0) 4 9855 111
 Fax: +972 (0) 4 9855 175
 E-Mail: salese@egmo.co.il
 www.egmo.co.il
ISRAEL



NEUMO-EGMO Spain S.L
 Tel: +34 977 524 914
 Fax: +34 977 524 898
 E-Mail: neumo-es@neumo-es.com
 www.neumo-es.com
SPAIN



HPT Inc.
 Tel: +845.452.1103
 +800.284.4478
 E-Mail: sales@hptinc.com
 http://www.hptinc.com/
U.S.A



Herrli AG
 Tel: +41 (0) 31 750 12 11
 Fax: +41 (0) 31 750 12 00
 E-Mail: info@herrli.net
 www.herrli.net
SWITZERLAND



NEUMO Polska Sp. z.o.o
 Tel: +48 (0) 46 833 4306
 Fax: +48 (0) 46 832 5626
 E-Mail: neumo@neumo.pl
POLAND



NEUMO Turkey
 Tel: +90 (212) 875 01 41
 Fax: +90 (212) 875 23 13
 E-Mail: info@neumo.com.tr
 www.neumo.com.tr
TURKEY



NEUMO Budapest Kft
 Tel: +36 (1) 3174177
 +36 (1) 3185982
 Fax: +36 (1) 266 8765
 E-Mail: neumo@neumo.hu
 www.neumo.hu
HUNGARY



NEUMO LLC
 Tel: +84 908475382
 E-Mail: Minh.Vietnam@neumo.de
 www.awh.eu
VIETNAM



NEUMO - VARGUS (Shanghai)
 Trading Co., Ltd
 Tel: +86 (21) 51688300
 Fax: +86 (21) 51688380
 E - Mail: info@neumo.com.cn
CHINA



NEUMO UK Ltd.
 Tel: +44 (0) 1952 583 999
 Fax: +44 (0) 1952 583 958
 E-Mail: stainless@neumo.co.uk
 www.neumo.co.uk
UNITED KINGDOM



AWH Armaturenwerke (D)
 Hötensleben GmbH
 Tel: +49 (0) 39405 92 0
 Fax: +49 (0) 39405 92 111
 E-Mail: info@awh.de
 www.awh.de



NEUMO
 Tel: +353 (0)21 4975540
 Cel: +353 (0)87 2330469
 E-Mail: dosullivan@neumo.de
 www.neumo.de/en/
IRELAND



Damstahl a/s (Denmark)
 Tel: +45 (0) 8794 4000
 Fax: +45 (0) 8794 4150
 E-Mail: ds@damstahl.com
 www.damstahl.dk
DENMARK

Damstahl GmbH (D)
 Tel: +49 (0) 2173 797 0
 Fax: +49 (0) 2173 797 274
 E-Mail: ds@damstahl.de
 www.damstahl.de



Damstahl a/s Oslo (N)
 Tel: +47 5615 1570
 Fax: +47 5615 1571
 E-Mail: dano@damstahl.com
 www.damstahl.no
NORWAY



Damstahl a/b (Sweden)
 Tel: +46 87 61 71 00
 Fax: +46 87 61 14 05
 www.damstahl.se
SWEDEN

Gebr. Rieger GmbH+Co. KG (D)
 Tel: +49 (0) 7361 5702 0
 Fax: +49 (0) 7361 5702 51
 E-Mail: info@rr-rieger.de
 www.rr-rieger.de
GERMANY



Semiconductor



Bio-Pharm



Hygienic